

HERCULES

COMMERCIAL FRONT LOADER



Proven technology with years of experience.



E-Z Pack

HERCULES

Commercial Front Loader SPECIFICATIONS

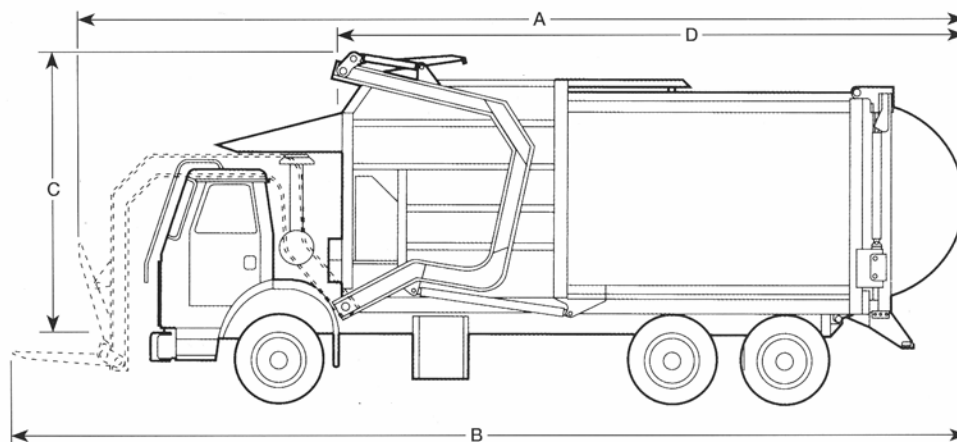

MODEL NO.	35 Cu. Yd. (26.8 Cu. Mt.)	37 Cu. Yd. (28.3 Cu. Mt.)	40 Cu. Yd. (30.6 Cu. Mt.)	44 Cu. Yd. (33.6 Cu. Mt.)
A OVERALL LENGTH (FORKS PERPENDICULAR)	374.75" (9519 mm)	386.75" (9823 mm)	410.75" (10,433 mm)	422.75" (10,738 mm)
B OVERALL LENGTH (FORKS PARALLEL)	418.75" (10,636 mm)	425.75" (10,814 mm)	449.75" (11,424 mm)	461.75" (11,728 mm)
C HEIGHT (ABOVE CHASSIS FRAME)	119.25" (3029 mm)			
D LENGTH (BODY & GATE)	253" (6426 mm)	265" (6731 mm)	289" (7341 mm)	301" (7645 mm)
INSIDE WIDTH (HOPPER)	80.25" (2038 mm)			
INSIDE WIDTH (BODY)	88" (2235 mm)			
INSIDE HEIGHT (BODY)	98" (2489 mm)			
INSIDE HEIGHT (HOPPER)	93.25" (2369 mm)			
WIDTH OVERALL	96" (2438 mm)			
HOPPER WIDTH	80.25" (2038 mm)			
HOPPER LENGTH	101" length (2565 mm)			
WEIGHT (FULL EJECT)	17,400 lbs. (7893 kg.)	17,600 lbs. (7983 kg.)	18,200 lbs. (8256 kg.)	18,400 lbs. (8346 kg.)

CONSTRUCTION AND OPERATIONAL DETAILS	
Hopper Floor	1/4" Pl. (6.35 mm) 155,000 min. 400 BHN
Hopper Sides (Upper)	10 Ga. (3.42 mm) 100,000 min.
Hopper Sides (Lower)	3/16" Pl. (4.76 mm) 100,000 min.
Body Floor	3/16" Pl. (4.76 mm) 100,000 min.
Body Sides	10 Ga. (3.42mm) 100,000 min.
Body Roof	10 Ga. (3.42 mm) 100,000 min.
Gate Bubble	10 Ga. (3.42 mm) 100,000 min.
Packing Cylinders (2) full eject	5-1/2" (140 mm) 119,275 lb. packing force
Interlaced 10" (254 mm) longitudinals under 10 yd. (7.6 cu. mt.) Hopper	
Flange type 13" (330 mm) wide longmembers under body.	
Lift arm cylinders (2)	4-1/2" (114 mm) (D.A.)
Fork cylinders (2)	4" (102 mm) (D.A.)
Tailgate cylinders (2)	3" (76 mm) (D.A.)
Hopper door cylinder	3" (76 mm) (D.A.)
Hydraulic oil tank	47 Gallon (178 liters)
Hydraulic pump	42 G.P.M. @ 1200 RPM (159 liter/min.)
Hydraulic filters	6 micron return/3 micron breathers
System operating pressure	2,500 PSI
SPECIAL NOTE: Chassis equipped with diesel engine requires full variable speed governor.	

Standard Features:

- 100 gallon (380 liters) sump created by curved rear body floor
- Body floor, sides and roof radiused for greater strength
- Bolt-in guide shoes 4 point packing blade shoes without removing packing blade
- Automatic latch/unlatch tailgate
- 25 second packing cycle time
- 20 second container dump time
- Automatic packing cycle
- Lower packing blade face exerts 62 PSI on load
- Filtration 6 micron return with electric dirt indicators in cab
- High mount light package
- Air controls
- Sliding hopper cover
- Mounting bracket for strobe and camera
- Tailgate maintenance props

Optional Equipment:

- 10,000 lift arm capacity
- Front body enclosure with valve cover
- Partial raise service hoist
- Camera systems
- Wash out tank
- Front body sump doors or sump overlay
- Fork stop kit
- Installation of body or fork mount scale system
- Residential package
- Outside controls
- Container floodlight
- L.E.D. lamps
- Strobe/rotating beacon lights
- Adjustable forks
- "Fuel saver" hydraulic system
- High pressure filter
- 10" cabshield extension
- Hopper floodlight
- East coast lightweight body
- Plastic clean-out shovel
- Spare filter package

HOLTZ 
INDUSTRIES, INC.

200 South Terrace Court
Newark, OH 43055
Phone: 1-800-535-0104

Website: www.holtzindustries.com