

A5-OR-250 TRAILER HOIST



Holtz Industries, Inc.
200 South Terrace Ct | Newark, OH 43055
TF: 1-800-535-0104 | Web: www.holtzindustries.com

The **A5-OR-250** trailer hoist is a heavy-duty hoist for use in the scrap industry. Designed to handle punishing loads, the 250 is engineered for durability and years of service.



*EX model shown

Available Models:
Deadlift (HH)
Extendable Tail (EX)
Inside/Outside Rail (IO)
Outside Rail (OR)



*EX model shown

All Galbreath products are designed to be compliant with ANSI standard container requirements.

Features

- ▶ Designed for hauling scrap and refuse
- ▶ 60,000 lb. manufacturer's rated capacity
- ▶ Handles 22-30' containers
- ▶ Proven Galbreath quality means the hoist is built to last
- ▶ Two outboard lift cylinders provide greater stability
- ▶ Available in OR, IO, EX and HH models
- ▶ Other trailers compatible for up to 39' containers in the A5 series
- ▶ Good return on investment
- ▶ High resell value

Options

- ▶ Lift axle
- ▶ Air ride suspension
- ▶ Tire carrier
- ▶ Wet kit
- ▶ Rear wing plate



Mobile Products Division



A5-OR-250 TRAILER HOIST

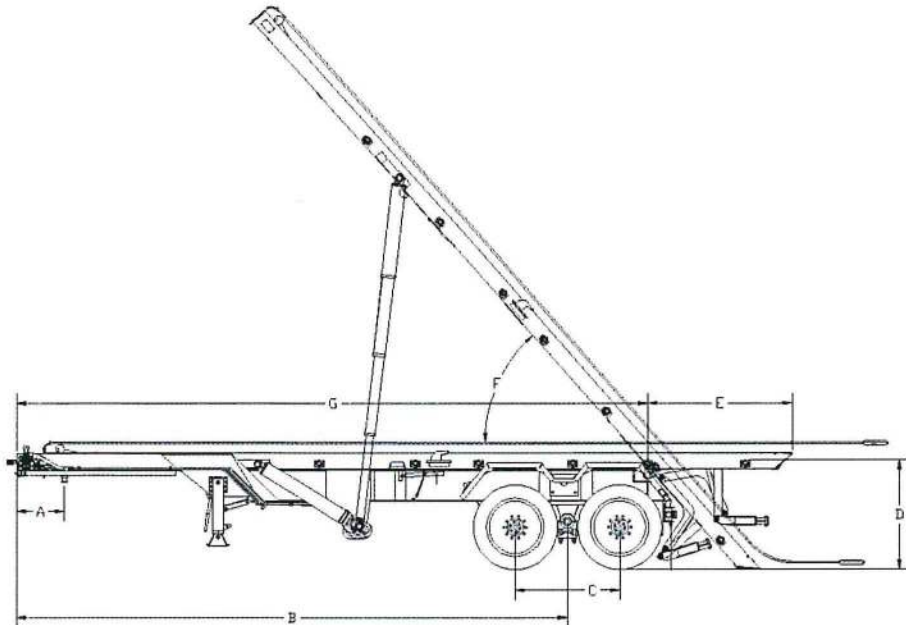

A = 18"
 B = 275 3/4"
 C = 53"
 D = 55 1/16"
 E = 72 5/8"
 F = 49°
 G = 316 1/4"

GENERAL TRAILER INFO

Overall Trailer Length	(G + E) = 32'5"
Weight	16,500 LBS
Dump Angle	(F) 49°
Ratchet / Hold Down System	Ratchet / stationary hold downs
Container Range	22' – 30' (22' – 26' for EX & HH Models)
Hoist Capacity	60,000 LBS (50,000 LBS HH Models)
GVWR Rating	60,000 LBS (50,000 LBS HH Models)
Rollers / Sheaves	ALL GREASABLE
Lighting	LED

STRUCTURES

Hoist Frame	8" X 4" X 1/2" Rect. Tubing ASTM A500 Grade C (3/8" EX)
Trailer Frame	16" X 36# W.F. I-Beam A36
Cable	7/8", 6 x 37 EXIWRC REGULAR RIGHT LAY
Finish / Paint	Two Part Epoxy Primer & Paint

AXLES, SUSPENSION AND BRAKING

Axles Rating	25,000 LBS
Suspension Rating	50,000 LBS Hutch Single Point Tandem
Landing Gear	200,000 LBS, 2 Speed
Tires	11R X 22.5 16 Ply
Wheels	10 Hole Hub Piloted
Fenders	Full Steel - 12 Gauge Front, 14 Gauge Rear
Brake System	ABS

HYDRAULICS

Lift Cylinders	6"-5"-4" X 118" DA TELESCOPIC
Winch Cylinders	4" DA, 3" GROUND, POLISHED & CHROME
Working Pressure	2,000 PSI
Maximum Pressure	2,500 PSI
Hoses	SAE 100R2 or Greater for 5,000 PSI Max, 2,500 PSI Working
Plumbing	Hydraulic Steel Tubing



Holtz Industries, Inc. | 200 South Terrace Ct | Newark, OH 43055
 TF: 1-800-535-0104 | Web: www.holtzindustries.com