



Holtz Industries, Inc.
200 South Terrace Court | Newark, OH 43055
TF: 1-800-535-0104 | Web: www.holtzindustries.com

Dual Pivot

DUAL PIVOT HOOK HOISTS

61 ¾" HOOK HEIGHT

MODELS: U6-DPHK

(DPHK) – **Dual Pivot Hook Hoists** are designed for higher hauling capacities and ease of use with the advantage of set hook heights. Ideal for the waste, recycling, landscaping, construction, and roofing industries, dual pivot hook hoists offer greater versatility and easier maneuverability than traditional roll-off cable hoists. Dual pivot hook hoists keep containers safely secured to the hoist frames during the dump cycle with rear container hold downs and a rear pivoting hinge. With simpler in-cab hoist operation, the U6-DPHK models improve operator safety and efficiency through faster cycle times.



Standard Features

- Inside air controls mounted in ergonomic power tower featuring Plug And Play™ wiring
- Back-up alarm & hoist up alarm with signal light in cab
- Secondary manual controls mounted outside on driver's side
- Outside frame rail stationary rear container hold downs
- Dual rear flanged rollers
- Ductile cast iron rear roller with bronze bushing
- Rear hydraulic stabilizer with 10" ground roller
- T1 steel fabricated fixed hook height at 61 ¾"
- In frame 6" O.D. rollers with bronze bushings
- Pintle adaptable rear apron and bumper assembly complete with DOT approved LED lighting
- Steel hydraulic tank side mounted with 3 micron filtration, dual sight/temp. gauge & air breather
- Dual hoist maintenance / safety props
- Warranty: limited lifetime on frame & 2-year limited on hydraulic system
- Customized engineering layouts ensure the best fit for each customer



Inside air controls in power tower

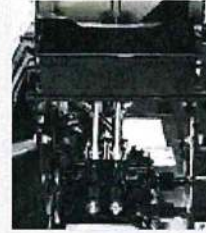

Secondary outside manual control valve

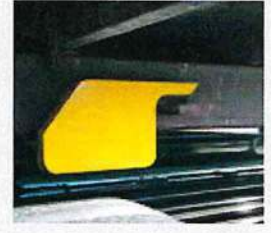

Outside frame rail stationary rear container hold downs



HD rear apron that is pintle adaptable with back up alarm and split bumpers with LED lighting and mud flaps



Steel hydraulic tank side mounted with 3 micron filtration, dual sight/temp gauge & air breather



Twin pivot assembly locks for dual pivot activation



Rear hydraulic stabilizer with 10" ground roller



T1 steel fabricated fixed hook height at 61 ¾"



Dual safety / maintenance props and inside rail rollers



Dual rear flanged rollers

FEATURE	U6-DFHK
Hoist main frame	DOMEX 11" formed Z-Rail
Jib frame/pivot tube	Structural tubing A500 grade C & A514 - T1 steel
Hydraulic pump	Gear type 37.5 GPM @1,500 RPM
Operating pressure	3,800 PSI
Hydraulic valve	2 Spool / 45 GPM w/ safety bypass
Oil reservoir	50-gallon steel tank w/ internal 3 micron return filtration
Lift cylinders	(2) Dual acting rod type
Jib cylinders	(1) Dual acting rod type
Hinge shaft	2" Solid steel
Front stops	Jib fully extended
Hold downs	Stationary rear container hold downs
Container stools	Inside rail 6" rollers w/ bronze bearings
Pickup Hook	A514 - T1 steel
Rear stabilizer*	10" Roller w/ bronze bearing - hydraulic cylinder actuated

*Only needed if uplift calculation is too high; chassis dependent

Available Options

- Pioneer[®] tarping systems
- Lift axles, tires and rims
- Additional containers hold downs
- Auxiliary hydraulic hook-ups / wet kits
- Steel, aluminum or poly fenders
- Toolbox styles and sizes (steel & aluminum)
- Pintle hook with gladhands
- Safety and LED work lights
- Back-up camera systems
- Scale systems
- Pass through hold downs
- Short stop option for hauling shorter containers



Pioneer[®] tarping systems



Toolbox styles and sizes (steel & aluminum)



Pintle hook with gladhands



Steel, aluminum or poly fenders



LED work lights



Back-up camera systems

U6-DPHK-224 shown with lift axle



Dual Pivot

Figure 1

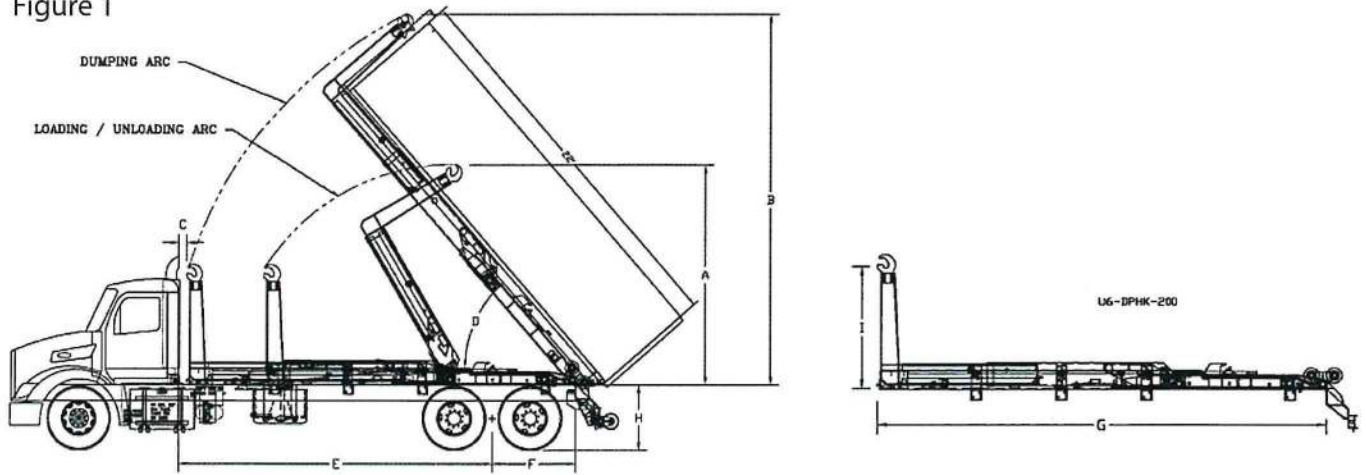

Notes for Figure 1

- 1 When recommending container lengths, weight distribution, fender interference and overhang are factors. Please consult your local ordinances when determining the model of hoist needed to suit your container needs.
- 2 Factory tested with recommended container length and water level load.
- 3 Total maximum height will depend on the container and frame height. Consult engineering for clearance.
- 4 Frame Height = Top of truck chassis frame to ground. Using 22 1/2" tires only. Tested w/ 43 3/4" frame height; any truck frame higher than 43 3/4" will change hoist capacities, dump angle and its ability to snatch onto the bar. For higher truck frames or using larger tires, consult engineering for clearance and capacity ratings.
- 5 This distance does not allow for a behind the cab (BTC) oil reservoir, tarper platform and or room to add a tarper; must add space for those items.
- 6 Air ride suspensions require up to 25" maximum after frame.
- 7 The rear stabilizer may not be necessary on all models. This will depend upon uplift calculations that can vary depending upon chassis configurations.

Specifications (Tandem Axle)	U6-DPHK-176	U6-DPHK-200	U6-DPHK-224
Recommended Container Size - ¹	16' to 20'	18' to 22'	20 to 24'
Rated Hoist Capacity @ Hook Height ²	60k lbs. @ 61 3/4"	60k lbs. @ 61 3/4"	60k lbs. @ 61 3/4"
A - Max. Hook Height (Load/Unloading) ^{3,4}	133 3/4"	133 3/4"	133 3/4"
B - Max. Hook Height (Dumping) ^{3,4}	224 3/4"	232 3/4"	250 1/2"
C - Back of Cab to Hoist ⁵	3"	3"	3"
D - Dump Angle	58°	49°	49°
E - (CT) Cab to Trunnion ⁵	176"	200"	224"
F - After Frame ⁶	14 1/2" to 25"	14 1/2" to 25"	14 1/2" to 25"
G - Hoist Length	213"	232"	252"
H - Frame Height ⁴	43 3/4" or less	43 3/4" or less	43 3/4" or less
I - Hook Height	61 3/4"	61 3/4"	61 3/4"
Lift Cylinders - (2) dual acting	7" x 3 1/2" x 81"	7" x 3 1/2" x 81"	7" x 3 1/2" x 81"
Jib Cylinder - (1) dual acting	4" x 2 1/2" x 48"	4" x 2 1/2" x 48"	4" x 2 1/2" x 52"
Rear Stabilizer ⁷	Standard*	Standard*	Standard*
Approximate Weight w/ Standard Features ⁷	7,800 lbs.	7,969 lbs.	8,395 lbs.
Cycle Times @ 37.5 GPM & 1,500 RPM			
Extending Dump	43 sec.	43 sec.	43 sec.
Retracting Dump	32 sec.	32 sec.	32 sec.
Extending Jib	4 sec.	4 sec.	4 sec.
Retracting Jib	3 sec.	3 sec.	3 sec.

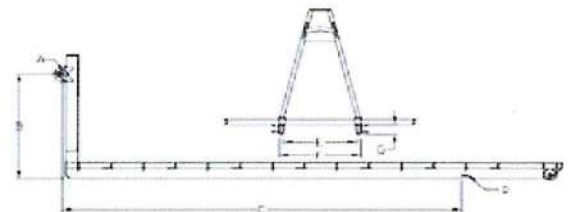

Lift Bar Dia.	Hook Ht.	Bar to Hold Down	Hold Down Locations	Inside Sill Width	Outside Sill Width	Long Still Ht.
A	B	C	D	E	F	G
2 1/2"	61 3/4"	138" min.	Outside	36 1/2" min.	41 1/2" max.	6"

Minimum Truck Requirements (Tandem Axle)

Axle rating: 18,000 front / 44,000 rear
 Truck torque: 418 ft. lbs.

*The chart below is an example of how to calculate the chassis section modulus (RBM/PSI = SM). Regardless of the frame YIELD and RBM, the min. SM must be 20 in³ or more per each frame rail.

Truck Channel Ht.	RBM	Yield (PSI)	RBM/PSI = SM in ³
10" or more (single wall)	2,400,000- 4,500,000	120,000 psi	20 in ³ - 37.5 in ³
10" or more (double wall)	2,000,000- 4,000,000	100,000 psi	20 in ³ - 40 in ³

Note: The single walled 120k psi with RBM less than 2,400,000 would not be acceptable because its SM would fall below the 20 in³ minimum specification (2,300,000/120,000 = 19.17 in³). For frames less than 10" consult engineering.

Distributed by: Holtz Industries, Inc.
 200 South Terrace Court | Newark, OH 43055
 TF: 1-800-535-0104 | Web: www.holtzindustries.com

