

ROLL-OFF CABLE HOISTS



Holtz Industries, Inc.

200 South Terrace Court | Newark, OH 43055

TF: 1-800-535-0104 | Web: www.holtzindustries.com



Shown with optional reverse mount lift cylinders.

Inside/Outside Rail (IO) cable hoists are designed to carry both inside and outside rail containers, maximizing versatility.

» **30,000 to 75,000 lb. capacity**

» **Single and tandem axle**

IO SERIES

STANDARD FEATURES

Ease of operation

- Centered cab-mount Power Tower
- Plug n' Play wiring system
- Pintle ready rear aprons
- Standard inside air control

Safety

- Automatic front container spring-loaded locking system and rear container hold-downs
- Heavy-duty safety props
- Fold-up ICC bumper
- Backup alarm and hoist up alarm with signal light on dash
- Optional hoist up speed-limiting parameters

* **Factory mount models**

Durability

- 3 micron filtration system with dual viscosity oil
- Two part epoxy primer and paint*
- Field tested heavy duty rear hinge
- Hoist frames are huck bolted to chassis*
- Shock-absorbing sub-frame
- Oil reservoir is filter cart ready
- LED lighting
- Lifetime warranty on frame and two-year warranty on hydraulics

Quality

- Lean manufacturing process, along with engineering, solid modeling and stress analysis testing, ensure quality, consistent product every time
- Customized engineering layouts are created based on customers' chassis to ensure compatibility

AVAILABLE OPTIONS

- Reverse cylinder mount
- Pintle hook applications
- Various fender selections
- Auxiliary hydraulic hook-ups
- Scale systems
- Pioneer Rack'n Pinion tarping systems



GALBREATH QUALITY

Holtz Industries, Inc.
200 South Terrace Court | Newark, OH 43055
TF: 1-800-535-0104 | Web: www.holtzindustries.com

Standard Features



3 micron (pictured at right) filtration system with dual viscosity oil reduces contamination, required maintenance and down time

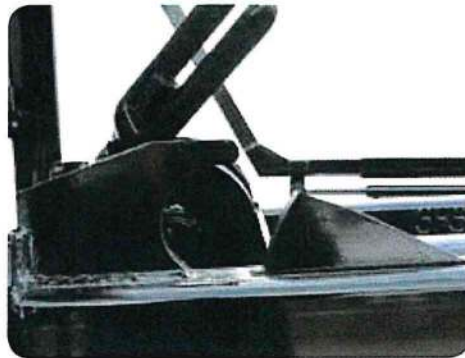

Automatic front container spring-loaded locking system and rear container hold-downs help ensure container remains in place



"Plug n' Play" wiring system eliminates crossed wires, loose connections, corrosion and splices; allows for easy light replacement



Oil reservoir is filter cart ready, reducing maintenance costs



Air assist ICC bumper



Hoist frames are huck bolted to chassis, providing unmatched strength and durability (factory mount only)

Available Options

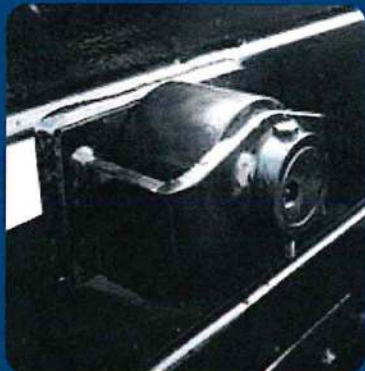

Rear skid plate with outboard supported rollers



Optional rear ratchet straps on all cable models



Pintle ready rear aprons allow for the addition of a pintle hook and easy upgrade to a trailer package

SPECIFICATIONS

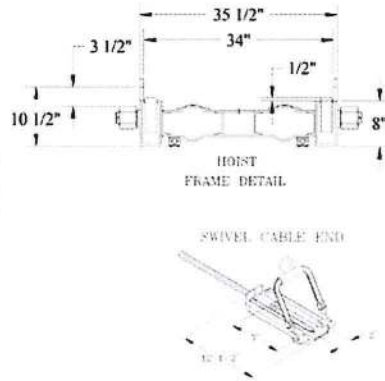
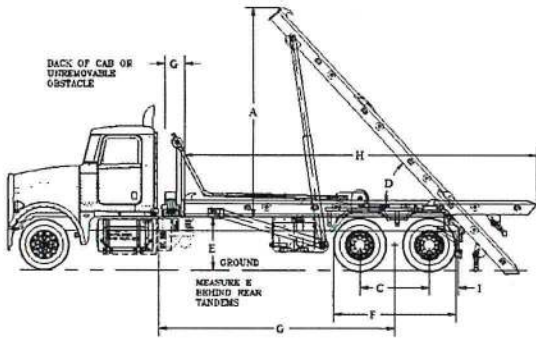

Notes for chart below:

- 1 When recommending container lengths, weight distribution, fender interference and overhang are factors
- 2 Factory tested with recommended container length and water level load
- 3 Frame = top of truck chassis frame
- 4 This distance does not allow for a behind-the-cab oil reservoir, tarper platform and room to add a tarper. Must add distance for these items
- 5 Using 22.5" tires only. For larger tires, consult representative

FEATURES

SINGLE AXLE

TANDEM AXLE

Hoist frame	8" x 3" x 3/8" A500 grade C tubing	8" x 4" x 1/2" A500 grade C tubing
Subframe	4" x 3" x 1/4" A500 grade C tubing	3" x 2" x 3/16" A500 grade C tubing
Front stop	1 1/2" plate steel	1 1/2" plate steel
Front safety lock	Automatic spring loaded	Automatic spring loaded
Hinge shaft	1 1/2" solid steel	2 1/2" solid steel
Cable anchors	4 cable clamps	4 cable clamps
Cable end	Pear eye	Swaged end swivel eye
Rear hold downs	1/2" plate located for standard Wastequip containers	3/4" plate located for standard Wastequip containers
Operating pressure	1,850 psi	1,850 psi
Hydraulic pump	Gear type 17.5 gpm @ 1,500 rpm	Gear type 35 gpm @ 1,500 rpm
Hydraulic valve	2 spool / 25 gpm with safety bypass	2 spool / 45 gpm with safety bypass
Oil reservoir	20 gallon with 25 micron filter and fill	50 gallon with 25 micron filter and fill
Outside rollers	4" OD with bronze bearings	4" OD with bronze bearings
Cable sheaves	10" OD with bronze bearings	10" OD with bronze bearings
Working points	Greasable	Greasable
Chassis front axle	9,000 lbs. (min) capacity with power steering	18,000 lbs. (min) capacity with power steering
Chassis rear axle	22,000 lbs. capacity (minimum)	44,000 lbs. capacity (min)
Frame modulus	17.5 in ³	24.0 in ³
Torque required	103 foot pounds of torque	248 foot pounds of torque

	U3-10-156	U5-10-174	U5-10-194	UT-10-174	UT-10-194	U75-10-174	U75-10-194	UH-10-174	UH-10-194
FEATURE	SINGLE AXLE	TANDEM AXLE	TANDEM AXLE	TANDEM AXLE	TANDEM AXLE	TANDEM AXLE	TANDEM AXLE	TANDEM AXLE	TANDEM AXLE
Recommended container size¹	14-20'	18-22'	20-24'	18-22'	20-24'	18-22'	20-24'	18-22'	20-24'
Rated capacity²	30,000 lbs.	60,000 lbs.	60,000 lbs.	60,000 lbs.	60,000 lbs.	75,000 lbs.	75,000 lbs.	75,000 lbs.	75,000 lbs.
A - Height above truck frame³	157 1/2"	163 1/2"	181 7/8"	163 1/2"	181 7/8"	163 11/16"	179 15/16"	165 3/16"	179 15/16"
B - Back of cab to hoist⁴ (add 12" for tarper or hard plumbing)	6"	6"	6"	6"	6"	6"	6"	6"	6"
C - Axle spread	N/A	51-55"	51-55"	51-55"	51-55"	51-55"	51-55"	51-55"	51-55"
D - Raised dump angle	51°	47°	48°	47°	48°	47°	47°	48°	48°
E - Top of truck frame to ground⁵	42"	46"	46"	46"	46"	46"	46"	46"	46"
F - Tire OD to OD	N/A	96" max	96" max	96" max	96" max	96" max	96" max	96" max	96" max
G - Clear Cab to Trunnion (CT) (add 12" for tarper or hard plumbing)	156"	174"	194"	174"	194"	174"	194"	174"	194"
H - Hoist length	246"	280"	300"	280"	300"	280"	300"	280"	300"
I - After frame	37 1/4"	23"	23"	23"	23"	23"	23"	23"	23"
Lift cylinders DA = double acting DAT = double acting telescopic	5" x 3" x 54" DA	6" x 4" x 72" DA	6" x 5" x 114" DAT	6-5-4" x 118" DAT	6-5-4" x 118" DAT	7" x 4" x 72" DA	6-5-4" x 118" DAT	6-5-4" x 118" DAT	6-5-4" x 118" DAT
Lift cylinders shaft	1 1/2" Solid	2 1/2" solid	2 1/2" solid	2 1/2" solid	2 1/2" solid	2 1/2" solid	2 1/2" solid	2 1/2" solid	2 1/2" solid
Winch cylinders DA = double acting	5" x 3" x 66" DA	7" x 3" x 80" DA	7" x 3" x 90" DA	7" x 3" x 80" DA	7" x 3" x 90" DA	7" x 3" x 80" DA	7" x 3" x 90" DA	7" x 4" x 90" DA	7" x 4" x 90" DA
Approx. weight with standard features	5,900 lbs.	8,044 lbs.	8,506 lbs.	8,073 lbs.	8,368 lbs.	8,920 lbs.	9,270 lbs.	9,113 lbs.	9,513 lbs.

Holtz Industries, Inc.

200 South Terrace Court | Newark, OH 43055

TF: 1-800-535-0104 | Web: www.holtzindustries.com

HOIST DRAWINGS

IO Series

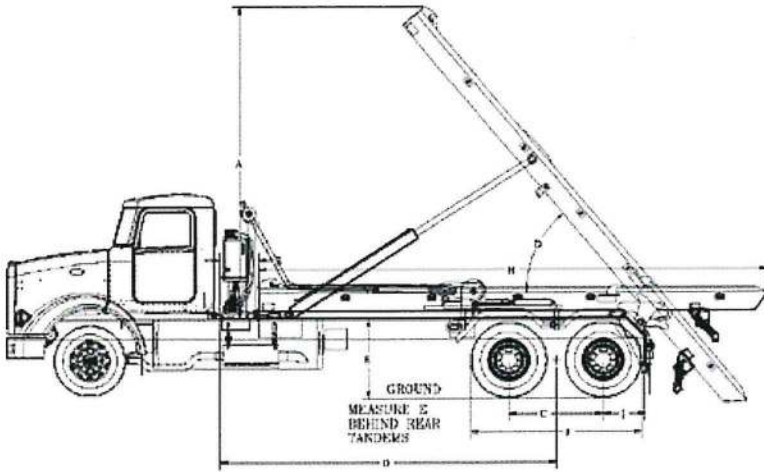

HOIST
FRAME DETAIL

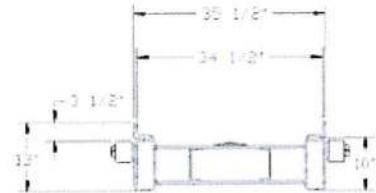

EX Series

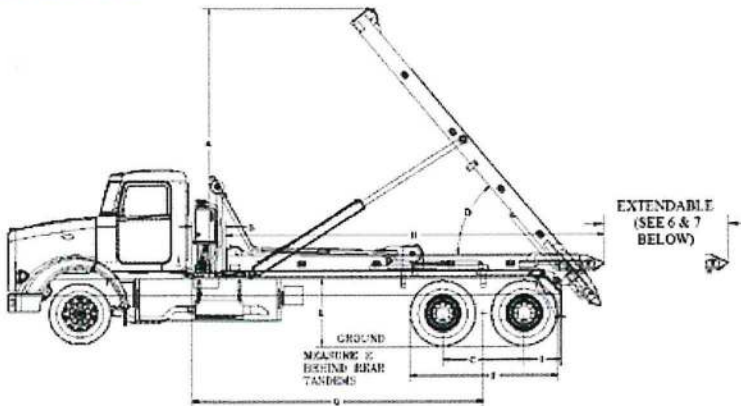

HOIST
FRAME DETAIL



SWIVEL CABLE END

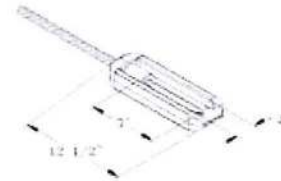

HH Series

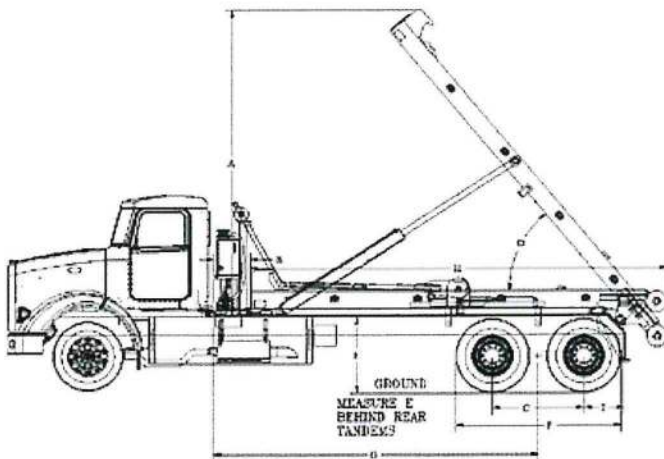

HOIST
FRAME DETAIL

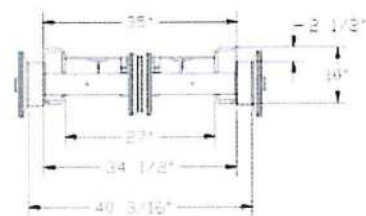

KNUCKLE CABLE END

AVAILABLE OPTIONS

- Reverse cylinder mount
- Pintle hook applications
- Various fender selections
- Auxiliary hydraulic hook-ups
- Scale systems
- Pioneer Rack 'n Pinion tarping systems

TRUCK SPECIFICATIONS

Single axle:

- Front axle: 9,000 lbs. (min.) capacity
- Rear axle: 22,400 lbs. (min.) capacity
- 50,000 psi or more chassis frames
- Minimum section modulus = 17.5 in.³

Tandem axle:

- Front axle: 18,000 lbs. (min.) capacity
- Rear axle: 44,000 lbs. (min.) capacity
- 50,000 psi or more chassis frames
- Minimum section modulus = 24 in.³

CONTAINER REQUIREMENTS

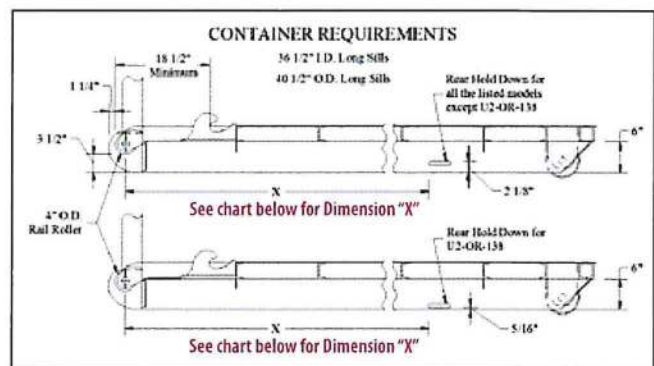
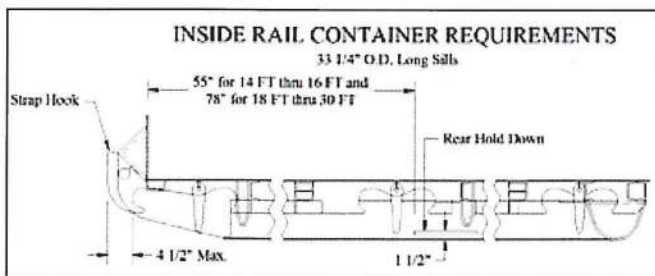

DIMENSION "X"*								
CONTAINER LENGTHS								
MODEL	12 ft.	13 ft.	14 ft.	15 ft.	16 ft.	17 ft.	18 ft.	19 ft. +
All (except U2-EX/IO/OR-138 & U3-EX/IO/OR-156)	Additional info. needed	145 1/2"	145 1/2"	149"	149"	173"	173"	191"
U2-EX/IO/OR-138	Length not recommended	Length not recommended	158"	158"	158"	158"	158"	Length not recommended
U3-EX/IO/OR-156	Length not recommended	Length not recommended	149"	173"	173"	173"	173"	173"

* Dimension "X" is center of rail roller to front of rear hold down

NOTE: Tolerance for all models is +1"/-0" except where container lengths are not recommended or where more information is required.



Holtz Industries, Inc.

200 South Terrace Court | Newark, OH 43055

TF: 1-800-535-0104 | Web: www.holtzindustries.com