



Holtz Industries, Inc. | 200 South Terrace Court | Newark, OH 43055

TF: 1-800-535-0104 | Web: www.holtzindustries.com

SINGLE PIVOT

SINGLE PIVOT HOOK HOISTS

DUAL HOOK HEIGHTS

MODELS: U20/13-HK & U25/18-HK

Single Pivot Hook Hoists are purpose-built for several industry applications including waste, construction, recreation, auto, and more. With dual hook height capabilities, the U20/13-HK and U25/18-HK models provide versatility for the user to lift containers of varying heights and weights. Equipped with ergonomic air controls, these models improve operator safety and efficiency.



Standard Features

- Inside air controls mounted in ergonomic Power Tower featuring Plug And Play™ wiring
- Backup Alarm & Hoist Up Alarm with signal light in cab
- Secondary manual controls mounted outside on driver's side
- Steel front jib locks
- Rear transition container support with rear ratchet hold downs
- Rear roller is ductile cast iron 6" OD and flared sides with bronze bushing
- Slide-out rear frame for mounting on various chassis & to haul longer containers
- Adjustable hook heights - 36.5" & 54"
- Bolt on roller stools with 4" OD rollers & bronze bushings allow for smooth loading/unloading
- Rear apron & bumper assembly complete with LED lighting and pintle/reese ready
- 3 Micron return filtration inside of steel tank with dual sight/temp gauge
- Warranty: 2-year limited on hydraulic system
- Customized engineering layouts ensure the exact fit for each customer
- Engineered and manufactured in the U.S.

FEATURE	
Hoist main frame	Adjustable - structural tubing A500 Grade C
Jib frame/pivot tube	Structural tubing A500 Grade C & A514 - T1 steel
Hydraulic pump U20/13-HK	Gear type 17.5 GPM @ 1,500 RPM
Hydraulic pump U25/18-HK	Bent Axis Piston Pump 24 GPM @ 1,500 RPM
Operating pressure	U20/13 - 3,800 PSI U25/18 - 4,000 PSI
Hydraulic valve	2 spool / 25 gpm with safety bypass
Oil reservoir	20-gallon steel tank with internal 3 micron return filtration
Lift cylinders	(2) dual acting rod type
Jib cylinders	(1) dual acting rod type
Hinge shaft	2" solid steel
Front stops	Jib fully extended
Hold downs	Heavy duty nylon ratchets
Container stools	Rollers with bronze bearings
Pickup hook	A514 - T1 steel
Adjustable hook height	Pull pin - 36" & 54"

Galbreath



Competitor



3 Micron return filtration inside of tank



Front jib lock



Pull (2) pins to slide in/out dual hook height adjustment



Rear bumper with LED lights



20-gallon steel hydraulic tank side mounted w/ dual sight/temp gauge



Inside air controls center mounted in ergonomic Power Tower featuring Plug And Play™ wiring



Outside controls



Flared rear roller and roller stools



Rear container support & hold downs

*Factory mount models

Holtz Industries, Inc. | 200 South Terrace Court | Newark, OH 43055
TF: 1-800-535-0104 | Web: www.holtzindustries.com

Available Options

- Pioneer tarping systems
- Toolbox in various sizes
- Pintle hook or reese style hitch for trailer packages
- Fenders in various sizes and shapes made with steel, aluminum or poly
- Hard plumbing
- Auxiliary hydraulic hook ups/wet kits
- Cable controls
- Container hold downs
- Lift axles
- Tires and rims (steel, aluminum)



Pintle hook & reese style hitch



Fender options in steel, aluminum or poly



Pioneer tarping systems

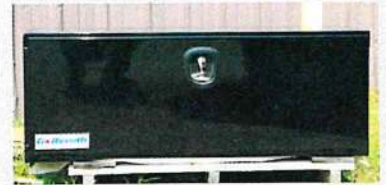

Toolbox styles and sizes

U25/18-HK shown with optional Pioneer HR2500 PowerGlide Tarp System and steel half round fenders



SINGLE PIVOT

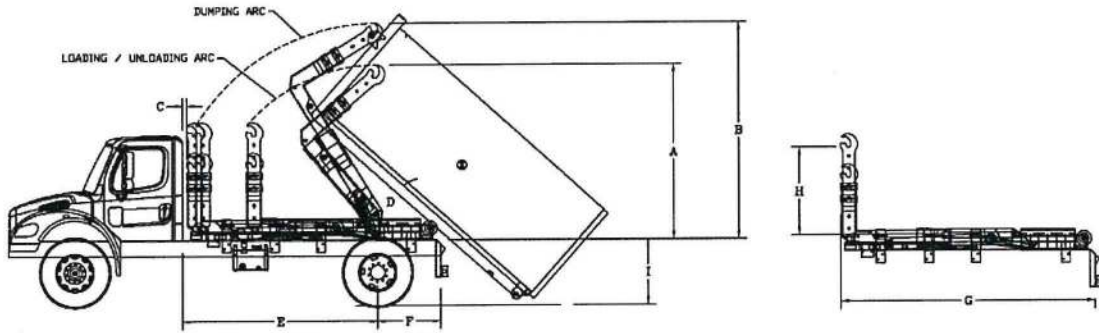

Notes for Chart

- 1 When recommending container lengths, weight distribution, fender interference and overhang are all factors that need to be considered.
- 2 Factory tested with recommended container length and water level load.
- 3 Total maximum height will depend on the container and frame height. Consult engineering for clearance
- 4 Frame Height = Top of truck chassis frame to ground. Using 22.5" tires only. Tested with 42" frame height; any truck frame higher than 42" will change hoist capacities, dump angle and its ability to snatch onto the bar. For higher truck frames or using larger tires, consult engineering for clearance and capacity ratios. Optimized dump angle is achieved with the following containers: 12' on 120" CA and 14' on 132/144" CA's.
- 5 This distance does not allow for a behind the cab (BTC) oil reservoir, tarper platform and or room to add a tarper; must add distance for those items.
- 6 Air ride suspensions require 25" of after frame.

SPECIFICATIONS (SINGLE AXLE)	U20/13-HK-120	U20/13-HK-132	U20/13-HK-144
	U25/18-HK-120	U25/18-HK-132	U25/18-HK-144
Recommended container size	10' to 14' or 12' to 16'	12' to 16'	12' to 16'
Rated hoist capacity @ hook height ² (U20/13)	13,000 lbs. @ 36" 20,000 lbs. @ 54"	13,000 lbs. @ 36" 20,000 lbs. @ 54"	13,000 lbs. @ 36" 20,000 lbs. @ 54"
Rated hoist capacity @ hook height ² (U25/18)	18,000 lbs. @ 36" 25,000 lbs. @ 54"	18,000 lbs. @ 36" 25,000 lbs. @ 54"	18,000 lbs. @ 36" 25,000 lbs. @ 54"
A - Max. hook height (loading/unloading) ^{2,4}	96" or 107"	96" or 107"	96" or 107"
B - Max. hook height (dumping) ^{2,4}	124" or 132"	124" or 132"	124" or 132"
C - Back of cab to hoist ⁵	2 1/4"	2 1/4"	2 1/4"
D - Dump angle (depends on container length) ⁴	60° - 41°	60° - 41°	60° - 41°
E - (CA) cab to axle ⁵	120"	132"	144"
F - After frame ⁶	38 1/2" or 62 1/2"	50 1/2"	38 1/2"
G - Hoist length	156"	180"	180"
H - Hook length	36" & 54"	36" & 54"	36" & 54"
I - Frame Height ⁴	42" or less	42" or less	42" or less
Lift Cylinders - (2) dual acting (U20/13)	5" x 3" x 52"	5" x 3" x 52"	5" x 3" x 52"
Lift Cylinders - (2) dual acting (U25/18)	5" x 2 1/2" x 52"	5" x 2 1/2" x 52"	5" x 2 1/2" x 52"
Jib Cylinder - (1) dual acting	3" x 2" x 37"	3" x 2" x 37"	3" x 2" x 37"
Approx. weight with standard features (U20/13)	3,719 lbs.	3,719 lbs.	3,719 lbs.
Approx. weight with standard features (U25/18)	3,730 lbs.	3,730 lbs.	3,730 lbs.

CYCLE TIMES	3,800/17.5 (U20/13) & 4,000/17.5 (U25/18)
Extending Dump	30 sec. (U20/13) & 22 sec. (U25/18)
Retracting Dump	19 sec. (U20/13) & 14 sec. (U25/18)
Extending Jib	4 sec. (U20/13) & 3 sec. (U25/18)
Retracting Jib	2 sec. (Both models)

Minimum Truck Requirements (Tandem Axle)

Axle Rating: 8,000 Front / 18,000 Rear
Truck Torque: 212 ft. lbs.

*The chart below is an example of how to calculate the chassis section modulus (RBM/PSI = SM). Regardless of the frame YIELD and RBM, the min. SM must be 15.5 in³ or more per each frame rail.

Truck Channel Ht.	RBM	Yield (PSI)	RBM/PSI = SM in ³
10" or More (single wall)	1,500,000 - 3,000,000	120,000 psi	12.5 in ³ - 25 in ³
10" or More (double wall)	1,500,000 - 3,000,000	100,000 psi	15 in ³ - 30 in ³

Note: the single walled 120k psi with RBM less than 1,860,000 would not be acceptable because its SM would fall below the 15.5 in³ minimum specification (1,850,000/120,000 = 15.42 in³). For frames less than 10" consult engineering.

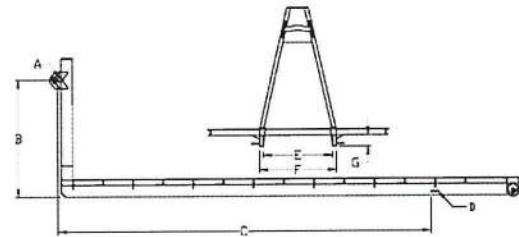

Lift Bar Dia.	Hook Ht.	Bar to front of hold down	Hold Down Locations	Inside Sill Width	Outside Sill Width	Long Sill Ht.
A	B	C	D	E	F	G
2 1/2"	36"	138" min.	Inside & Outside	36 1/2" min.	41 1/2" min.	4 1/4"
2 1/2"	54"	127 1/2" min.	Inside & Outside	37 1/2" min.	41 3/4" min.	6"

Distributed by:

Holtz Industries, Inc. | 200 South Terrace Court | Newark, OH 43055
TF: 1-800-535-0104 | Web: www.holtzindustries.com