

# LOADMASTER

## EXCEL

high performance rearloader

this data is NOT the Excel - "S" product

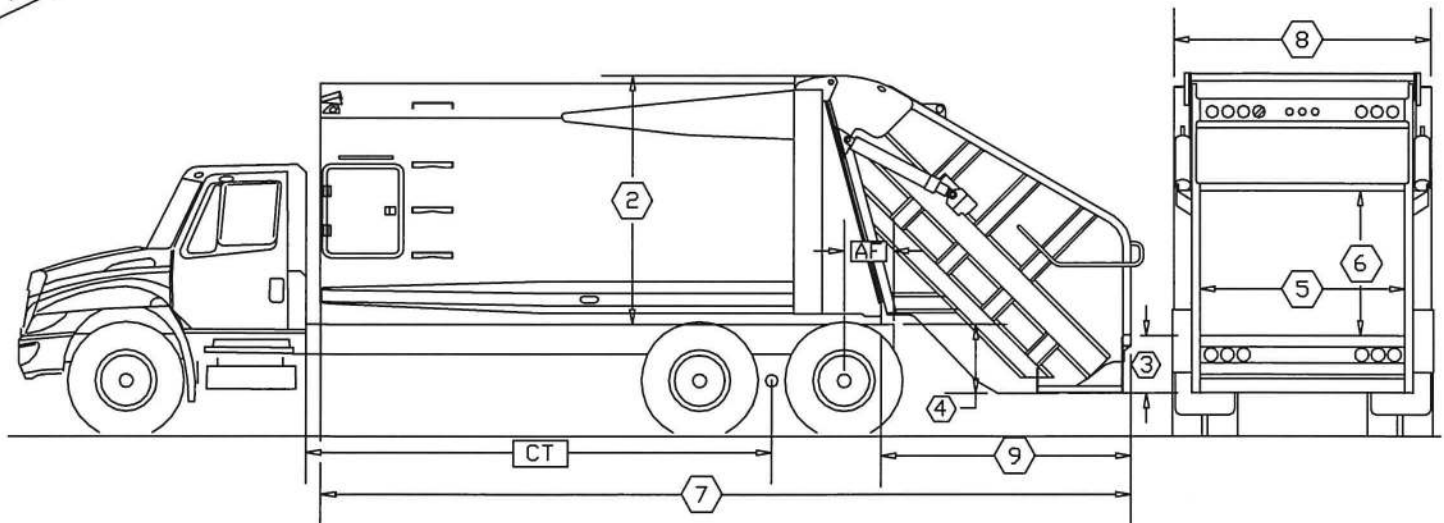

### DIMENSIONAL SPECIFICATIONS

1	AVAILABLE BODY VOLUMES →	20 YD <sup>3</sup>	25 YD <sup>3</sup>	31 YD <sup>3</sup>
2	HEIGHT ABOVE CHASSIS FRAME	93 1/2	93 1/2	93 1/2
3	DEPTH OF HOPPER	20 1/4	20 1/4	20 1/4
4	HOPPER BELOW CHASSIS FRAME	24 1/4	24 1/4	24 1/4
5	HOPPER INSIDE WIDTH	75	75	75
6	HOPPER OPENING HEIGHT	60	60	60
7	OVERALL LENGTH	274	304	351
8	OVERALL WIDTH	95 3/4	95 3/4	95 3/4
9	REAR OF BODY TO REAR OF TAILGATE	94	94	94
10	APPROX BODY WEIGHT	15,100 LBS	16,000 LBS	17,200 LBS
11	LOAD SILL BELOW CHASSIS FRAME	4 INCHES	4 INCHES	4 INCHES
12	HOPPER CAPACITY	3.7 YD <sup>3</sup>	3.7 YD <sup>3</sup>	3.7 YD <sup>3</sup>
13	HEIGHT ABOVE FRAME (WITH GATE RAISED)	184	184	184

### CHASSIS RECOMMENDATIONS

BODY SIZE	MINIMUM GVWR	MINIMUM FRONT GAWR	MINIMUM REAR GAWR	CT	MINIMUM AF
20 YD <sup>3</sup>	46,000	12,000	34,000	140"	26"
25 YD <sup>3</sup>	52,000	12,000	40,000	174"	26"
31 YD <sup>3</sup>	60,000	16,000	44,000	208"	26"

Holtz Industries, Inc.  
 200 S Terrace Ct | Newark, OH 43055  
 TF: 1-800-535-0104  
 Web: [www.holtzindustries.com](http://www.holtzindustries.com)

## EXCEL ... SPECIFICATIONS

### Material Specifications-Body

Body sides	8 ga. high tensile
Body floor	7 ga. high tensile
Body roof	8 ga. high tensile
Floor longitudinals	3" x 8" x 1/4" high tensile boxed channel
Ejector's track channel	1/4" "hat" channel
Body structural upgrades available (thicknesses and alloys)	

### Material Specifications-Tailgate

Lower tailgate sides	3/16" T-1 abrasion resistant
Upper tailgate sides	3/16" high tensile in "sweep" zone
	10 ga. high tensile above
Hopper floor	1/4" T-1 alloy
Separator panel	3/16" T-1 alloy abrasion resistant
Tailgate structural upgrades available (thicknesses and alloys)	

### Material Specifications-Blades

Ejector's face panel	10ga high tensile
Ejector's reinforces	1/4" high tensile
Ejector's shoes	UHMW polyethylene
Sweep's face panel	1/4" T-1 alloy
Sweep pusharms	1/2" high tensile
Slide face blade	7ga high tensile
Blade's wrist pin & axle	3" dia. medium carbon cold finished
Slider's shoeing	nylatron nsm & uhmw polyethylene

### Hydraulic Specifications

Reservoir	42 gallon "In-Body"	Sweep cylinders (2)	5" bore
Pump	Piston Pump (6.6 cubic inches per rev)	Slider cylinders (2)	5" bore
Pump flow	42 gallons per minute	Gate lift cylinders (2)	4 3/4" bore
Max system pressure	2950 psi	Ejector telescopic (1)	4-stage (6.5/5.5/4.5/3.5)
Suction filter	100 mesh	Body-mounted valve	2 function sectional
Return filter	16 micron tank top	Tailgate-mtd. valve	3 function
sectional			

### Electrical Specifications

Wire	14ga sxl	Switches	centralized, in cab panel
Wire identifiers	color & function labeling	Lights	grommet-mounted
Harnessing	multi-section; braid covering		
Harness connects	Deutsch aircraft type		
Wire connects	heat shrink sealed		

### Some standard features

Epoxy primer paint	Chromed cylinder rods
Undercoating	Cushioned slide and sweep cylinders
Manual tailgate buckles	Fully accessorized oil reservoir
Body access door with ladder	Bolt-on riding steps
Full complement of lights	Rear tailgate-mounted mudflaps
Quick change shoeing	Color coded control levers

### Some available options

Hot shift and air shift PTOs	Automatic tailgate latches
Work lights	"Customer-preferred" choices
Strobe lights	Tool box
Drum winch for containers	70 Gallon "Frame-Mtd" Tank
Roof cable-type reever; Kick bar	Cart Tippers (and/or CT "Hydarulics)



Holtz Industries, Inc.  
 200 S Terrace Ct | Newark, OH 43055  
 TF: 1-800-535-0104  
 Web: www.holtzindustries.com