

LOADMASTER

LEGACY 3 SERIES

mid range rearloader

"SHORT" Lengths

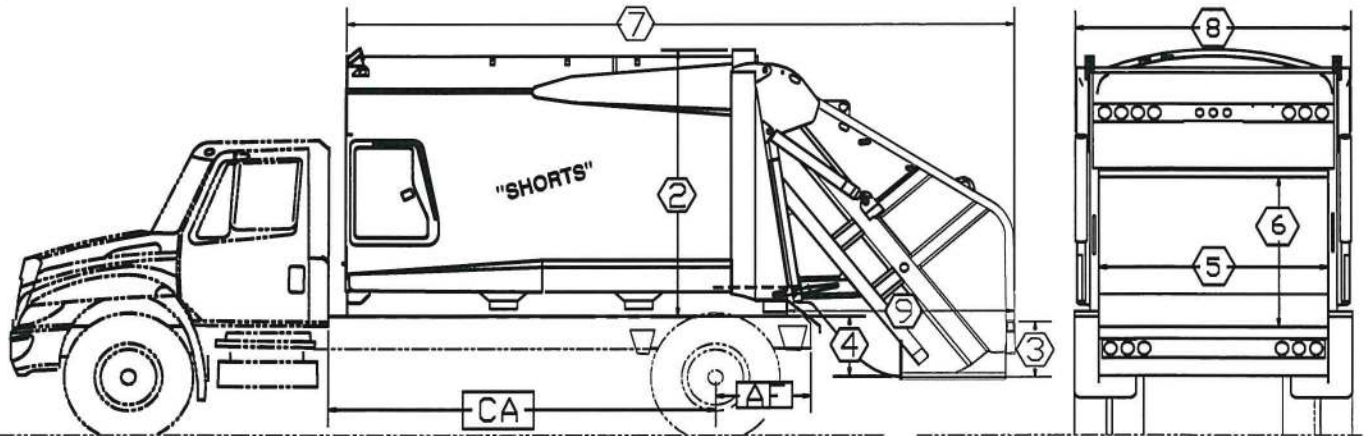

This Product Data Sheet is ONLY for "SHORT" length Legacy's (on Single Rear Axle chassis)

DIMENSIONAL SPECIFICATIONS for SHORT length LEGACY's

1 AVAILABLE BODY VOLUMES →	Ⓢ16 YD ³	Ⓢ18 YD ³	Ⓢ20 YD ³	Ⓢ25 YD ³
2 HEIGHT ABOVE CHASSIS FRAME	95 1/2	95 1/2	95 1/2	95 1/2
3 DEPTH OF HOPPER	19	19	19	19
4 HOPPER BELOW CHASSIS FRAME	25 1/2	25 1/2	25 1/2	25 1/2
5 HOPPER INSIDE WIDTH	80	80	80	80
6 HOPPER OPENING HEIGHT	60	60	60	60
7 OVERALL LENGTH	221	238	249	271
8 OVERALL WIDTH	96	96	96	96
9 REAR OF BODY TO REAR OF TAILGATE	81	81	81	81
10 APPROX BODY WEIGHT	12,100 LBS	12,300 LBS	12,700 LBS	13,400 LBS
11 LOAD SILL BELOW CHASSIS FRAME	2 1/2 INCH	2 1/2 INCH	2 1/2 INCH	2 1/2 INCH
12 HOPPER CAPACITY	3 YD ³	3 YD ³	3 YD ³	3 YD ³
13 HEIGHT ABOVE FRAME (WITH GATE RAISED)	174	174	174	174

Employ ONLY 22.5 inch wheels & tires for any Legacy3 (do not spec 19.5 inch)

Recommended Rear Tires for the "25S yard (only)" is 315R80-22.5 (if chassis is a S.R.A.)

If the Legacy 25S (or 20S) are to be "rare" TANDEM AXLE Chassis....see separate Product Data Sheet

LOADMASTER reserves the right to revise product specifications and without obligation.

CHASSIS RECOMMENDATIONS for SHORT length LEGACY's

BODY SIZE	MINIMUM GVWR	MINIMUM FRONT GAWR	MINIMUM REAR GAWR	CA	MINIMUM AF
Ⓢ 16 YD ³	30,000	9,000	21,000	128"	34"
Ⓢ 18 YD ³	30,000	9,000	21,000	140"	34"
Ⓢ 20 YD ³	33,000	10,000	23,000	152"	34"
Ⓢ 25 YD ³	39,000	12,000	27,000	170"	34"

Holtz Industries, Inc.
200 S Terrace Ct
Newark, OH 43055
TF: 1-800-535-0104
Web: www.holtzindustries.com

LEGACY 3 "BASE-PRODUCT" SPECIFICATIONS (16S, 18S, 20S, 25S VOLUMES ... "SHORT" Lengths)

Material Specifications-Body

Body sides	8 ga. high tensile (gr 80)
Body floor	7 ga. high tensile
Body roof	8 ga. high tensile (gr 80)
Floor longitudinals	3" x 10" x 3/16" boxed channel
Ejector's track channel	1/4" "hat" channel- elevated
	Many Body <i>structural</i> upgrades available (thicknesses and alloys)

Material Specifications-Tailgate (3-yard hopper)

Lower tailgate sides	3/16" T-1 (150ksi yield)
Upper tailgate sides	7 ga. high tensile in "sweep" zone
	10ga. high tensile above
Hopper floor	3/16" T-1 alloy
Separator panel	3/16" AR235 abrasion resistant
	Many Tailgate <i>structural</i> upgrades available (thicknesses, alloys)



Material Specifications-Blades

Ejector's face panel	HD rolled 3/16" Plate... 50KSI high tensile
Ejector's reinforces	1/4" high tensile
Ejector's shoes	UHMW polyethylene main shoes w/ NYLATRON GSM yaw & pitch shoes
Sweep's face panel	3/16" T-1 alloy (150ksi yield)
Sweep pusharms	1/2" high tensile
Slide face blade	7 ga. high tensile
Blade's wrist pin & axle	2 1/2" med-carb; induction-hardened; with Hard Bushed sweep's wrist pivot
Slider's shoeing	durable NYLATRON NSM (a "engineering-grade" polymer)

Holtz Industries, Inc.
 200 S Terrace Ct
 Newark, OH 43055
 TF: 1-800-535-0104
 Web: www.holtzindustries.com

Hydraulic Specifications

Reservoir	36 gallon	Sweep cylinders (2)	4 1/2" bore
Pump	Direct-couple PTO- or- crank driven Front Pump	Slider cylinders (2)	4 1/2" bore
Pump flow	30-33 gallons per minute	Gate lift cylinders (2)	3 1/2" single acting
Max system pressure	3200 psi	Ejector telescopic (1)	4-stage (6.5/5.5/4.5/3.5)
Suction filter	100 mesh	Body-mounted valve	2 function sectional
Return filter	15 micron <i>microglass</i> tank-top	Tailgate-mtd. valve	2 function sectional

(Note: 3-stage telescopic used for 16S and 18S...6.5/ 5.5/ 4.5)

Electrical Specifications

Wire	14ga sxl	Switches	"grouped" rockers; in cab panel
Wire identifiers	color & function labeling	Lights	LED grommet-mounted style
Harnessing	multi-section; braid covering		
Harness connects	Deutsch aircraft type		
Wire connects	heat shrink sealed		

Some standard features

Epoxy primer paint	Chromed cylinder rods	Regeneration (slider down function)
Undercoating	Cushioned slide and sweep cylinders	
Manual tailgate turnbuckle latches	Fully accessorized oil reservoir	
Body access door with ladder	Bolt-on riding steps	
Full complement of lights	Rear tailgate-mounted mudflaps	
Quick change shoeing	Color coded control levers	

Some available options

Hot shift and air shift PTOs	Tool box
Work lights/ Strobe lights	"Customer-preferred" choices
"ClearStep" Roll Bar (3 yard)	Lower'd Load-Sill (1-1/2" lower'd)
Drum winch for containers	Body sump "Clean Out door(s)"
Roof-mtd. cable-reever ("2-10")	Automatic Tailgate Locks Option
Cart Tipper hydrau circuits & instal	Slings-Lift (2 yard) for containers