

**New**  
**WideFoot**  
**Design**



**MODEL: PER-WD6080CB**

- ✓ High and deep dumping.
- ✓ Lifts ANSI Type B bins, up to 95 gal (400 lbs).
- ✓ 6-8 second cycle time, with 4 gpm.
- ✓ Features new & improved 27k widefoot actuator.
- ✓ Rear mounting plate & adjustable flow control included.
- ✓ Powder coated finish.
- ✓ 3 year limited warranty.

**Holtz Industries, Inc.**  
**200 South Terrace Court**  
**Newark, OH 43055**  
**TF: 1-800-535-0104**



## Benefits of Cart Lifters:

Lifters and bins eliminate broken bags & reduce trash on the ground, for cleaner city streets.

Using bins instead of bags reduces unwanted pests, for a healthier and safer community.

Lifters do the hard work, saving workers from bending over and lifting. This reduces worker fatigue.

Haulers using lifters and bins see fewer worker compensation claims from injuries..

Fewer injuries and less fatigue increases employee retention, reducing employee turnover and training.

Older, more experienced workforce leads to better customer service, faster route times, and better care for the equipment.



*Perkins is the only ISO certified lifter manufacturer in the United States. Privately held, and female owned, Perkins has proudly served the waste industry since 1973.*



**MODEL: PER-WD6080CB**

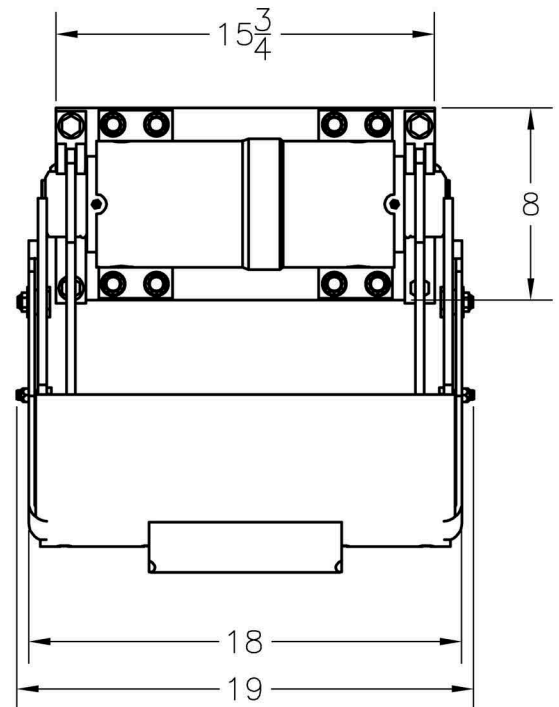
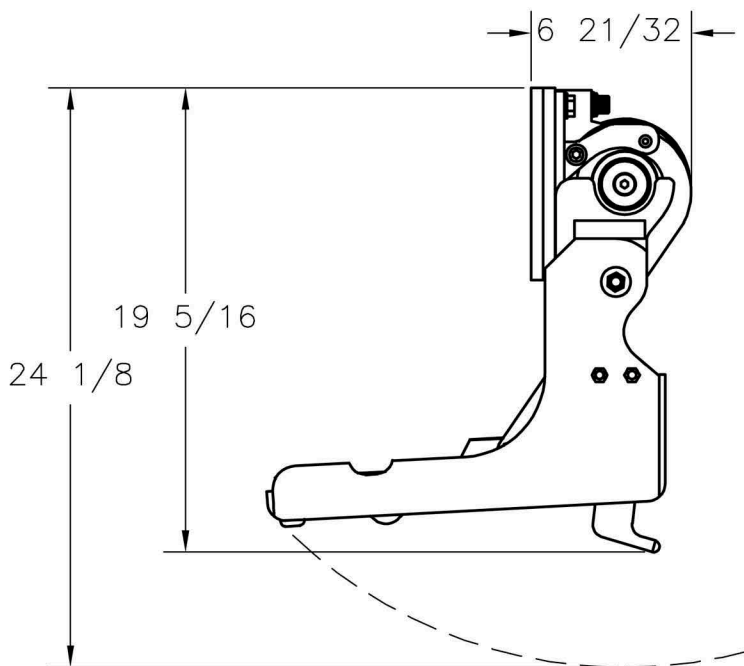

**Holtz Industries, Inc.**  
**200 South Terrace Court**  
**Newark, OH 43055**  
**TF: 1-800-535-0104**

