

CYCLE TIME: 6 – 8 SECONDS

FLOW RATE: 3.5 GPM

WEIGHT CAPACITY: 400 LBS

SET PRESSURE RELIEF TO 1650 PSI

COMPATIBLE WITH ANY ANSI TYPE B CARTS

HYDRAULIC COMPONENTS SOLD SEPARATELY

3 YEAR LIMITED WARRANTY

SHIPPING WEIGHT (NOT INCLUDING PACKAGING) 250 LBS

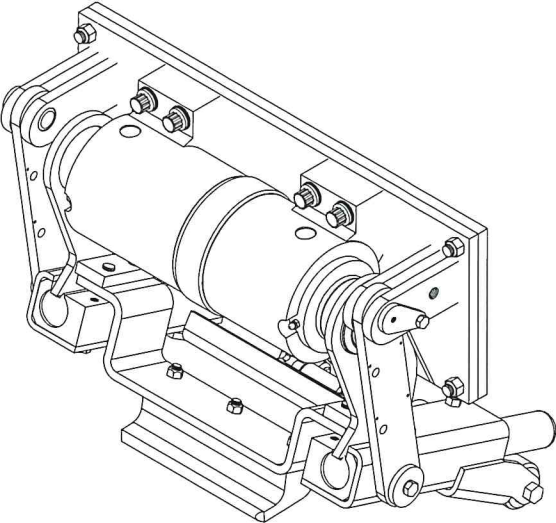

<b>Holtz Industries, Inc.</b> 200 S Terrace Ct Newark, OH 43055	RETURN QUOTES TO FAX#	DRAWING TYPE <b>ASSEMBLY</b>	THIRD ANGLE PROJECTION 	© PERKINS MFG CO. - ALL RIGHTS RESERVED, MAY NOT BE REPRODUCED OR COPIED IN ANY FORM WITHOUT EXPRESS WRITTEN CONSENT OF PERKINS MFG CO.	TITLE: <b>PER-D6620</b>
	ENGINEERING QUESTIONS	FIXTURE # -	TOLERANCES UNLESS OTHERWISE SPECIFIED	MARKING: <b>SEE BOM</b>	NEXT ASSEMBLY: -
	PLEASE DISPLAY THE CURRENT REVISION LEVEL ON ALL QUOTES, BILLING & CORRESPONDENCE.	<input checked="" type="checkbox"/> MFG IN-HOUSE <input type="checkbox"/> PURCHASE	FRACTIONAL ±1/64 ±1/32 DECIMAL ±.005 ±.015 ANGULAR ±1/2° ±1/2°	NOTES: REMOVE BURRS & CHAMFER SHARP EDGES 1/32X45° TO BE FREE OF RUST, HEAVY SCALE & WELD SPLATTER	THIS DATE INDICATES THE LATEST REVISION DATE: <b>REVISED: AUGUST 18, 2020</b> DESTROY OR MARK "OBSOLETE" ALL PREVIOUS PRINTS
	IF VENDOR HAS ANY SUGGESTIONS TO LOWER MANUFACTURING COSTS OR TO IMPROVE THE QUALITY, PLEASE CONTACT THE ENG. DEPT.	VENDOR REF# -	COCENTRIC CIRCLES ±.005	SURFACE FINISH TYPE UNLESS OTHERWISE SPECIFIED PIN SURFACES & DRILLED HOLES 63 ✓ PLASMA/LASER CUT SURFACES 250 ✓ MACHINED SURFACES 125 ✓	DWG. NO. <b>PER-D6620</b> PAGE <b>1/4</b> REV #
			DIM'S ARE IN INCHES DO NOT SCALE DWG	DRAWN: <b>I.Tovalin</b>	DATE OF CHECK: <b>08/18/2020</b>