

QUANTUM MD



Holtz Industries, Inc.
200 S Terrace Ct | Newark, OH | 43055
PH: 1-800-535-0104 | Web: www.holtzindustries.com



QUANTUM MD

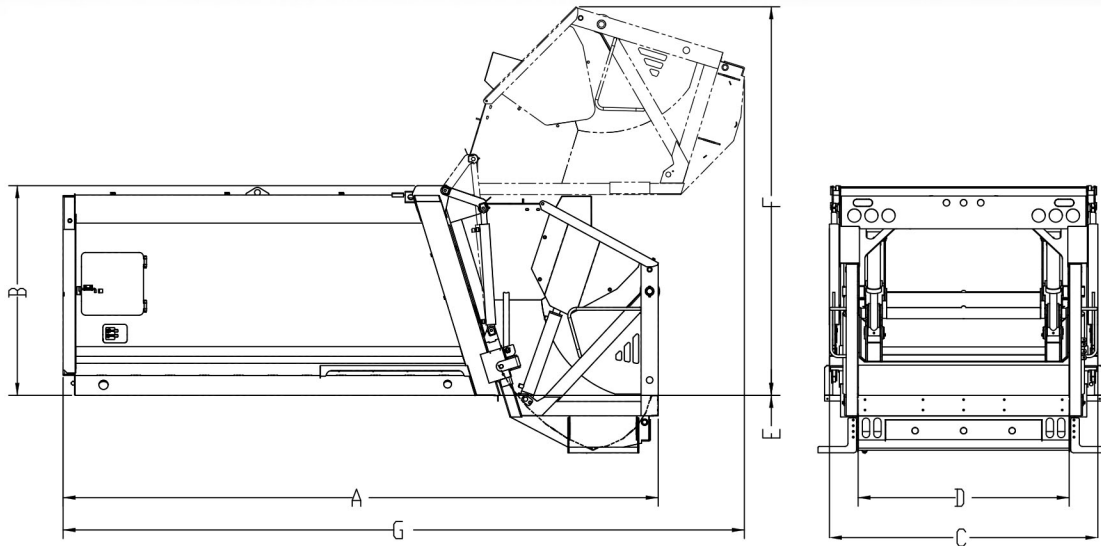

Body Specifications

	11 CU. YD.	13 CU. YD.
A: LENGTH OF BODY	191"	209"
B: HEIGHT OF BODY ABOVE CHASSIS	74"	74"
C: BODY WIDTH	94"	94"
D: HOPPER OPENING WIDTH	74"	74"
E: LOADING SILL BELOW CHASSIS FRAME	0"	0"
F: HOPPER OPENING HEIGHT	58"	58"
F: HEIGHT OF TAILGATE ABOVE CHASSIS FRAME (TAILGATE RAISED)	191"	191"
G: LENGTH OF BODY (TAILGATE RAISED)	221"	239"
CA: CAB TO AXLE MINIMUM	108"	126"
CF: MINIMUM USABLE CAB TO END OF FRAME	140"	158"
HOPPER CAPACITY	1.75 CU. YD.	1.75 CU. YD.
DYNAMIC HOPPER CAPACITY (CU.YD./MINUTE)	7 CU. YD.	7 CU. YD.
BODY WEIGHT	8,400 LBS	8,750 LBS

Minimum Chassis Requirements

	11 CU. YD.	13 CU. YD.
MINIMUM GVWR	29000 LBS *	33,000 LBS
FRONT AXLE	10,000 LBS	10,000 LBS
REAR AXLE	19000 LBS	23,000 LBS
REQUIRED FRAME HEIGHT	38" TO 40"	38" TO 40"
CHASSIS FRAME HEIGHT	36" - 39"	36" - 39" 210"

*11-YD QUANTUM CAN BE CONFIGURED FOR UNDER CDL WITH A 26,000 LBS MINIMUM GVWR (10,000 LBS FRONT AXLE & 16,000 LBS REAR AXLE). HOWEVER, THIS CONFIGURATION REDUCES THE ALLOWED LBS/CU. YD. BY 30% TO REMAIN AT OR BELOW MINIMUM GVWR.

Body Construction

- Roof: 11 gauge GR50
- Sides: 11 gauge GR50
- Floor: 11 gauge GR50
- Ejection Panel: 11 gauge GR50
- Sweep Face 3/16 GR100
- Tailgate side wall: 11 gauge GR50
- Upper, 7 gauge GR50 Lower
- Tailgate Floor: 3/16 AR400

Features

- High strength curved shell body
- Patented packing mechanism
- Rear Fenders standard
- Curved floor provides liquid sump
- Low body height
- Easy to maintain
- Pack cycle time of 15 seconds

Hydraulics

- Oil Reservoir: 25 gal. (94.6 liters)
- Oil Flow w/ Standard Pump: 25 GPM
- Operating Pressure: 3,000 PSI
- Engine RPM: 1,300 RPM
- Hose Burst Ratio: 4 to 1
- Return Filter: 10 micron
- Pack Cylinders: 4.0
- Sweep Cylinders: 4.0
- Eject Cylinders
 - 11 cu. yd: 4.5, 2 stage telescopic
 - 13 cu. yd: 5.0, 3 stage telescopic
- Tailgate Lift: 3.0

Optional Features

- Container roll bar with lip-and-latch
- Container lip-and-latch with 8,000 lb. drum winch
- Single & Dual tipper(s)
- Cart tipper tap-in-kits
- Work lights
- Strobe lights
- Broom and shovel holder
- Rear view color camera system



Holtz Industries, Inc.

200 S Terrace Ct | Newark, OH | 43055

PH: 1-800-535-0104 | Web: www.holtzindustries.com